

DMS CNC ROUTER

VERSION 3.1



AUTODESK
PIER 9

DMS CNC ROUTER

MACHINE CONTROLS

VERSION 3.1

THE DMS ROUTER IS CAPABLE OF MAKING COMPLEX, ACCURATE PARTS FROM YOUR CAD MODEL.

P. 2

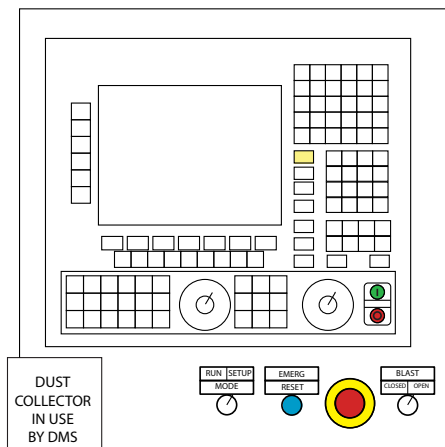
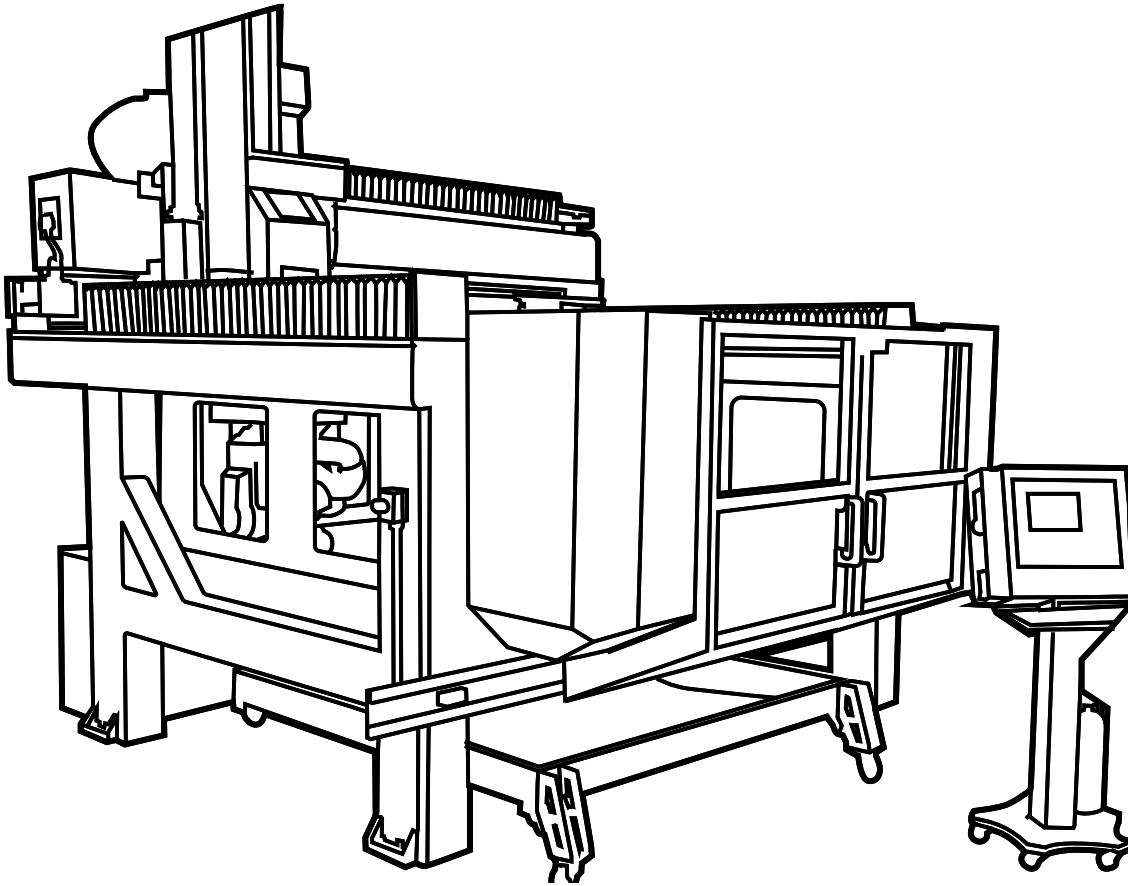

CONTROL PANEL

MATERIALS

i ALLOWED MATERIALS

- + Wood
- + Some plastics
- + Some foam

x BANNED MATERIALS

- + Metal
- + Carbon fiber and composites

? SEE SHOP STAFF FIRST

- + All other materials

USE PERSONAL PROTECTIVE EQUIPMENT WHEN OPERATING THE ROUTER.

P. 3



**PROTECT YOUR EYES
FROM FLYING CHIPS.**

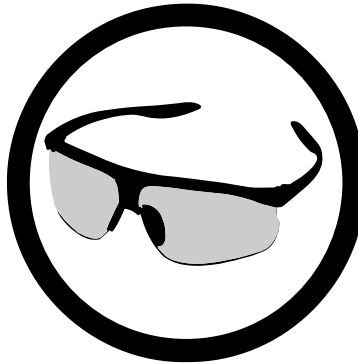

Always wear safety glasses.



**PRESS AN E-STOP
BEFORE REACHING INTO
THE MACHINE.**

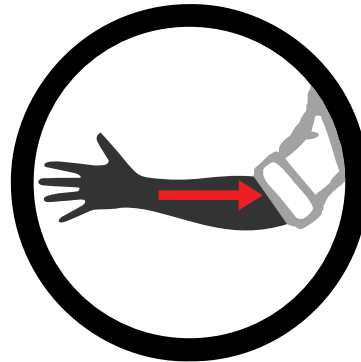

When reaching into the enclosure for any reason, turn off the machine or press an E-stop first.

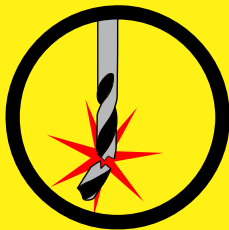

**NEVER LEAVE THE
MACHINE RUNNING
UNATTENDED.**



Stay within a few feet of the console or an e-stop button.

CONTROLLER

The controller is where you will run the router.

1. Screen
2. Letter keys
3. Number keys
4. Function keys
 - ▶ These keys select the on-screen option directly above the key.
5. Jog controls
6. Feed Rate Override
7. Cycle Start & Feed Hold buttons
8. Mode switch
9. Emergency reset button
10. E-stops
11. Blast gate switch
 - ▶ One on the console
 - ▶ Two on the machine chassis
 - ▶ One on the pendant

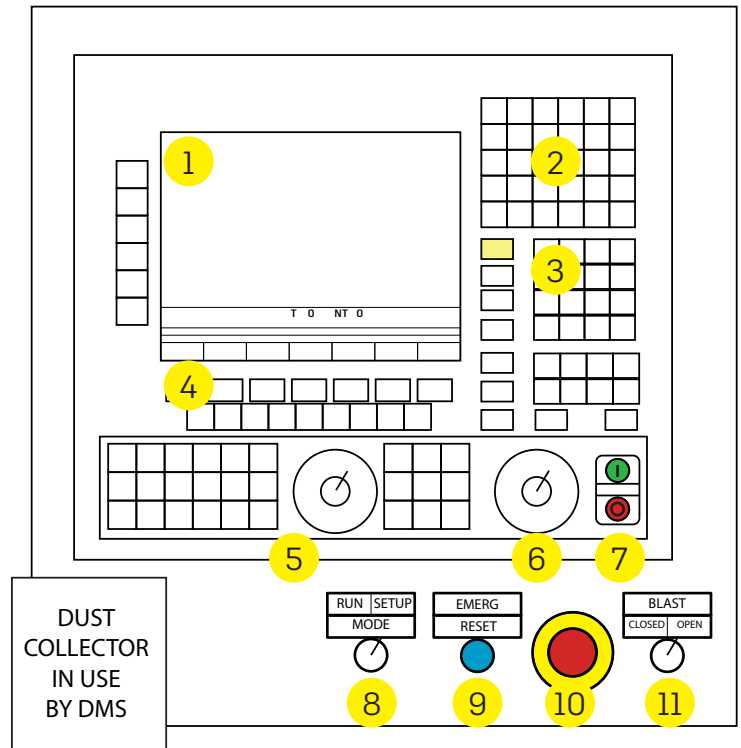

Jog Controls

To enter jog mode, press jog (F4) from the main menu.

There are four controls related to jogging.

1. Jog Increment Selector
 - ▶ Rotate the dial to select how far the head will jog for each button push.
 - ▶ The numbers represent 0.0001"
 - ▶ 1 = 0.0001" and 10000 = 1"
 - ▶ The wavy line all the way to the right selects continuous jog.
2. Axis buttons
 - ▶ Press the axis button to move that direction in the selected increment.
 - ▶ In continuous jog mode, the head will move as long as the button is down.
3. Rapid button
 - ▶ The head will move faster while the button is held down.
4. Feed Rate Override
 - ▶ Changes the feed rate - between 0 and 120%

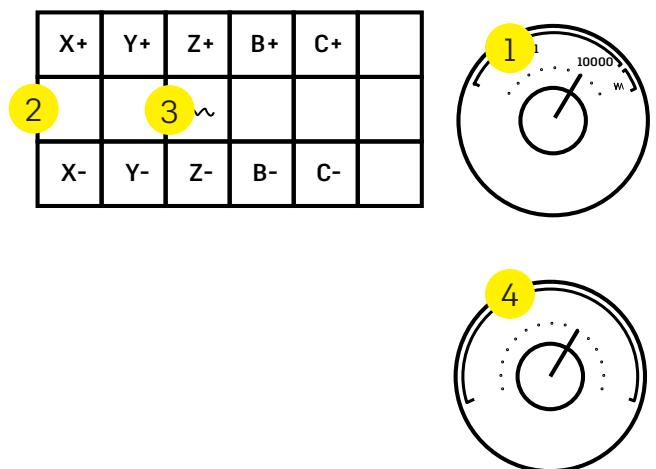

FOLLOW ALL THE STEPS, IN ORDER.

P. 5

MACHINE SPECIFICATIONS

The DMS CNC router is a large 5 axis router with the following specifications:

- + 12 horsepower spindle
- + 24,000 RPM maximum spindle speed
- + Work envelope of 5' x 5' x 4' (X, Y & Z)
- + Tool changer can hold up to 12 tools

REQUIRED FOR USE

Before you start your work, make sure you have the following materials:

- + An .nc file from your completed CAM file.
- + A thumb drive to copy the .nc file to the mill.
- + Setup Sheets from your CAM software.
- + A copy of this Quick Start Guide.

STEPS FOR SUCCESSFUL USE

To make a part, you need to complete each step in order.

1. Insert custom tools into the holders.
2. Start up the router.
3. Install & measure the tools.
4. Warm up the spindle.
5. Set the Work Offset (G54).
6. Load the program.
7. Run the program.
8. Clean up.

MEASURING MATERIAL

After preparing your material for the router, measure it carefully and change the setup in your CAM program if needed.

G53 & G54

Coordinates are displayed in inches.

G53 is the *Machine Coordinate System (Machine Home)*.

- + When the machine is in G53 mode the displayed coordinates are measured from the upper left corner of the machine.

G54 is the *Work Coordinate System (Work Home)*.

- + When the machine is in G54 mode the displayed coordinates are measured from the corner of your work (or wherever you set X, Y & Z).

To change modes from the main menu

- + Press **Jog** and **MDI** to enter MDI mode.
- + Type **G53** or **G54** & press **Cycle Start**.

(Upper left corner
inside the DMS)

G53

X0 Y0 Z0

G54

X0 Y0 Z0

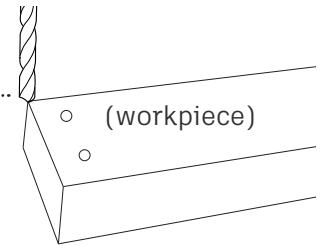

MOVING THE HEAD IN MDI MODE

From main menu, press Jog & MDI to enter MDI mode.

In the MDI mode, you can enter a coordinate for the machine to travel to.

1. Axis (X, Y, Z, B or C)[coordinate].
2. Set Feed Rate override to 0.
 - ▶ Be especially careful using MDI commands in Z.
3. Cycle Start.
4. Slowly increase feed rate.

You must be aware of what system (G53 or G54) you are in. The machine will move to the coordinates for the current system.

Example:

- + **X3 Cycle Start**
 - ▶ Will cause the head to move to X3. The other axes will not move.
- + **X5.125 Cycle Start Y-2 Cycle Start**
 - ▶ Will cause the head to move to X5.125, Y-2. The other axes will not move.

DUST COLLECTION

The *spindle dust collector* captures dust and chips at the spindle. It is a custom fiberglass shroud that can be controlled with "flood coolant" commands in the CAM program.

- + Use the dust collector shroud (coolant on) for any tool longer than 3 1/2", measured from the bottom of the spindle.
 - ▶ The shroud gets in the way of shorter tools, so keep it open (coolant off).
- + To manually open the shroud, enter M66 & press Cycle Start from the MDI menu.
- + To manually close the shroud, enter M65 & press Cycle Start from the MDI menu.

The woodshop dust collector must be used whenever the DMS is in operation.

1. Start the dust collector in the woodshop.
2. Place the "Dust Collector in Use by DMS" sign on the woodshop dust collector switch.
3. Open the Blast Gate switch on the DMS controller.

LIBRARY TOOLS VS CUSTOM TOOLS

Library tools

- + These tools are stored next to the router, and correspond to the DMS Pier 9 Tool Library that you imported into your CAM software.
 - ▶ Check the sign on the front of the router, and make sure you used the same library in your CAM program.
- + Each tool is engraved with a number that corresponds to its number in the library.
- + These tools are loaded into tool holders by Shop Staff.
 - ▶ Do not make any adjustment to any library tool.

Custom tools

- + These are the tools in your CAM program that are not in the library, such as drill bits.
- + You need to insert them into the tool holders.

ALL TOOLS (EVEN LIBRARY TOOLS) MUST BE GIVEN NUMBERS FROM 1-12 IN THE CAM PROGRAM, IN ORDER OF USE.

INSERT TOOLS INTO THE HOLDERS

There are two kinds of tool holders: drill chucks and *collets*. Both kinds should be held in the *tool vise* on the front of the mill while preparing custom tools.

Drill chucks

- + Only use for holding drill bits.
- + Tighten by applying force clockwise with the correct wrench for the chuck.

Collets & tool holders

1. Use a collet that is the same size as the *shank* of the cutting tool.
2. Snap the collet into the *collet nut*.
3. Screw the nut onto the collet a few turns.
4. Insert the cutter as deep as possible.
 - ▶ Grip the shank, not the flutes.
5. Tighten the collet nut with the wrench.

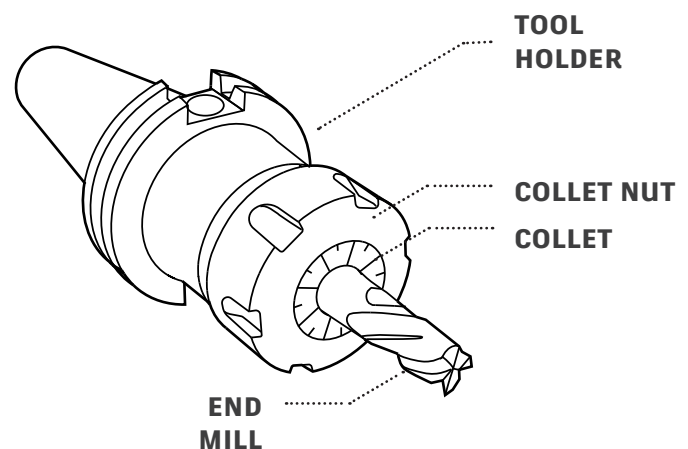

START UP THE ROUTER

Turn on the power

1. Throw the knife switch on the right side of the router.
2. Release all the e-stops by rotating clockwise.
3. If the blue Emergency Reset light flashes, press it for several seconds.
 - ▶ This should also clear on-screen errors.

Reference the axes

1. Open the Jog Menu. (F4)
2. Press Reference Search. (F1)
3. Select All Axes. (F7)
4. Press Cycle Start.
5. Check that the Feed Override is not set to zero.

Referencing the axes will hit the limit switch on all 5 axes and send the head to Machine Home.

This position is G53 X0 Y0 Z0 B0 C0.

After referencing, the spindle will move to Y-1.

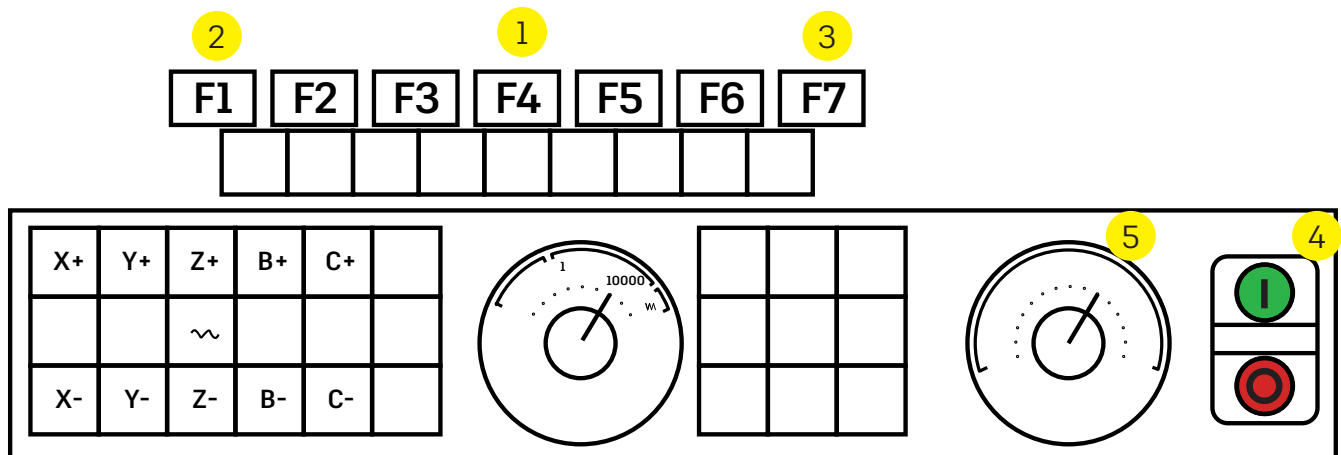

INSTALL & MEASURE THE TOOLS

Prepare the machine

1. Enter MDI mode.
 - ▶ Press Main Menu
 - ▶ Press **Jog** (F4)
 - ▶ Press **MDI** (F4)
2. Ensure the current tool is 0.
 - ▶ If it isn't, run the *Goodnight* program or see Shop Staff.
3. Ensure the tool magazine is empty.
4. Turn the Mode Key to Setup.
5. Open the spindle dust collector if needed.
 - ▶ Type **M66**.
 - ▶ Press **Cycle Start**.
6. Open the *tool probe cover*.

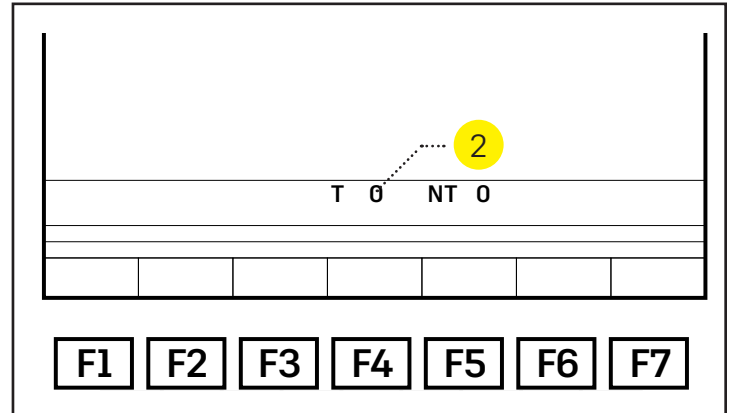

Perform these steps for each tool.
Close the tool probe cover when done.

Perform a tool change

You must be in MDI mode to change tools.

1. Type **T[tool number]** & press **Cycle Start**.
2. Type **M6** & press **Cycle Start**.
 - ▶ The machine will change the tool.
3. Verify the tool number on screen.
4. Press **ESC** to go up one level (jog mode).
5. Jog the head over to the doors.

Install the tool

1. Press **USER** (F5)
2. Press **Manual Tool Eject** (F1)
3. Press **Enable Tool Eject** (F1)
4. Insert the tool into the spindle.
 - ▶ Hold the tool in the spindle.
 - ▶ Press and release the green button on the spindle.
5. Press **EXIT** (F7) twice.

Measure the tool

1. Press **MDI** (F4).
2. Press **M[100+tool number]** & press **Cycle Start**.
 - ▶ Add 100 to the tool number (3 = M103)

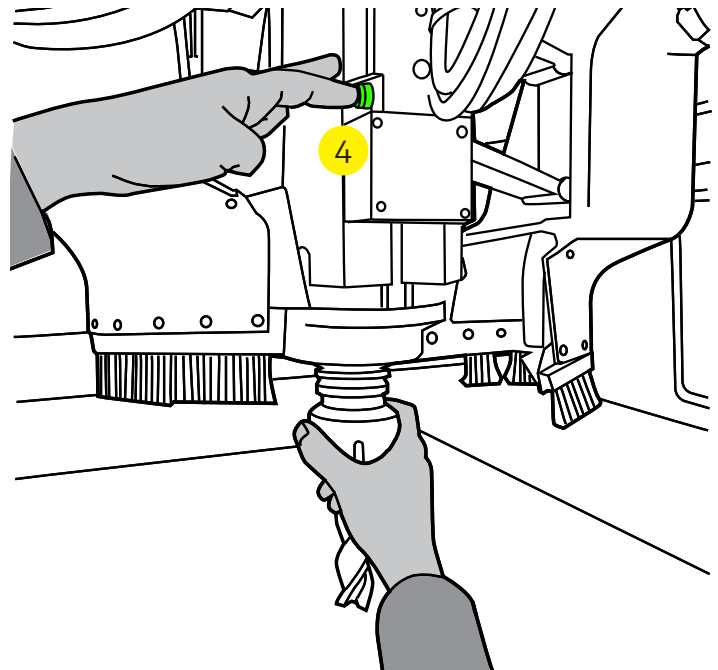

DETERMINE WORKHOLDING BEFORE CAM PROGRAMMING.

P. 10

WORKHOLDING OPTIONS

The bed of the DMS is a thick acrylic sheet. It is drilled in a 6" hole pattern, with 3/8"-16 threaded brass inserts in each hole.

- + Over-tightening a fastener can pull the insert out of the table.

Spoiler Board & Clamps

1. Clamp a spoiler board to the table.
2. Screw your material to the spoiler board.
 - ▶ Use a minimum of 4 screws, and more for large projects.

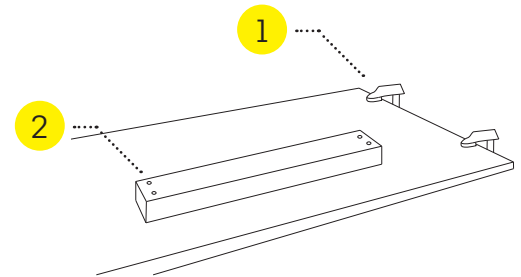

Make sure that the tool will not collide with a clamp or screw.

- ▶ Brass screws will not damage the tooling in case of a collision.

Threaded Inserts & Step Clamps

1. Hold the work with a *step clamp*.
 - ▶ The clamp should be level.
2. Support the end of the clamp with a *step block*.
3. Insert a threaded stud through the clamp into the table insert.
4. Tighten a nut on top of the clamp.
 - ▶ Use a minimum of 4 clamps, and more for large projects.

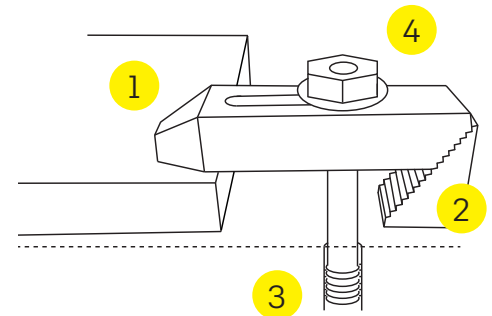

Make sure that the tool will not collide with a clamp.

Double Sided Tape

1. Clean the table and material.
 - ▶ Tape will not stick to damp or dusty materials or MDF.
2. Apply tape to your workpiece.
3. Press firmly to adhere the material to the table.
4. Test the adhesion before starting to cut your project.

Tape works better on short wide items than tall narrow ones.

SET THE WORK OFFSET (G54)

You must use the same Work Coordinate System (WCS) you chose in your CAM program.

You have 3 options when setting the Work Offset.

1. X, Y & Z at the corner
2. X & Y at the corner, Z in the middle
3. Air pass
 - ▶ X & Y at the corner, very high Z

Move the tool tip to Work Home.

1. Perform a tool change.
 - ▶ Choose a drill bit or small diameter tool to make finding your WCS easier and more accurate.
2. Jog the tool to Work Home.
3. Press **MDI**. (F4)
4. Type **G53** & press **Cycle Start**.

Set X & Y at the corner.

1. Press **ESC** to go up one level.
2. Press **User**. (F5)
3. Press **Load Zero Offsets**. (F2)
4. Press **Load G54 Offsets**. (F1)
5. Press **Clear All Offsets**. (F6)
6. Press **Yes**. (F1)
7. Press **Exit**. (F7)
8. Press **Load G54**. (F1)
9. Press **X & Y**. (F1) & (F2)
 - ▶ The status for each axis will change to *loaded*.
10. Press **Exit** three times. (F7)
 - ▶ This will return you to jog mode.

You have set your Work Coordinates for X & Y. Now, you must decide where to set your Z axis.

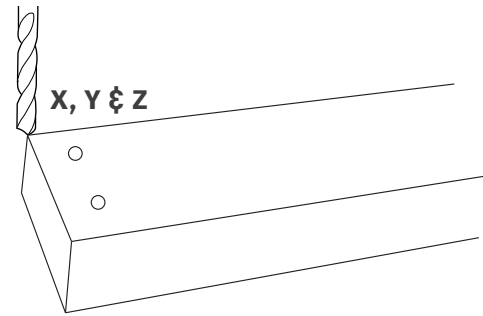

- 1 Measure X, Y & Z at the corner of the material.
 - + This is the fastest method.

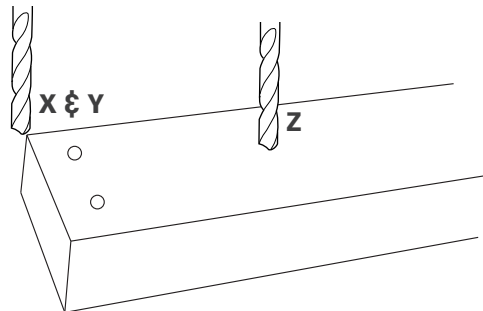

- 2 Measure X & Y at the corner. Measure Z in the middle of the part.
 - + This is a more accurate way of finding Z.



Measure X & Y at the corner. Measure Z high above the part.

- + Perform an air pass to check the toolpath.

REPOSITION & SET Z

The following steps will set Z, and also enable the machine to calculate exactly where the tool tip is located, even when moving the B & C axis.

1. If needed, jog the machine to where you want to set Z.
2. Press **MDI**. (F4)
3. Type **G48S0** (zero, not the letter) & press **Cycle Start**.
4. Type **G53** & press **Cycle Start**.
5. Type **D[tool number]** & press **Cycle Start**.
6. Type **G48S1** & press **Cycle Start**.
7. Press **ESC**.
 - ▶ You should be at the jog menu.
8. Press **User**. (F5)
9. Press **Load Zero Offsets**. (F2)
10. Press **Load G54**. (F1)
11. Press **Z**. (F3)
 - ▶ This will set your Z offset.

Confirm that your WCS has been correctly set.

1. Press **Exit** (F7) 3 times.
2. Press **MDI**. (F4)
3. Take a photo of the screen.
 - ▶ Include the X, Y & Z values.
 - ▶ This will allow you to return to Work Home in the case of a problem.
4. Type **G54** & press **Cycle Start**.
5. Check values of X, Y & Z.
 - ▶ Z should be 0.
 - ▶ X & Y will be 0, unless you jogged the machine to set Z.

WARM UP THE SPINDLE

The spindle must be warmed up before use. Follow these steps if you're the first person to use the machine for the day.

There should be a small diameter tool in the spindle.

1. Turn the key to Run mode.
 - ▶ The door must be closed.
2. Navigate to the Main Menu.
3. Press **Execute**. (F1)
4. Use the arrow keys to select the Spindle Warmup Program.
5. Press **Enter**.
6. Press **Cycle Start** to run the program.
 - ▶ The spindle will run for about 5 minutes.

Go over the pre-run checklist while the spindle is warming up.

PRE-RUN CHECKLIST

You're ready to run the program.

Confirm that these tasks have been completed.

- + All tools have been loaded.
 - ▶ Use the setup sheet.
 - ▶ Confirm that the tool numbers in CAM match the numbers in the machine.
- + You measured actual material size, updated the CAM program and regenerated the toolpaths.
- + The tool library file is the same version that you used in the CAM program.
- + All tools were measured for length.
- + Work Offset (G54) has been set.

LOAD THE PROGRAM

Post Process your file to the thumb drive from the CAM software.

- + The file must be a 6 digit number.
 - ▶ Do not use 900000 and above.
 - + The file must end with **.pim**
 - + The latest post processor is in the Pier 9 Tool Library Instructable.
1. Insert your thumb drive into the USB slot on the side of the machine, near the power switch.
 2. From the Main Menu, press **Utilities**. (F6)
 3. Press **Explorer**. (F7)
 - ▶ This will show the available memory sources.
 4. Navigate to USB Disk & press **Enter**.
 5. Navigate to your program.
 6. Press **Actions**. (F3)
 7. Select **Copy** and press **Enter**.
 8. Navigate to HARD DISK/prg.
 9. Press **Actions**. (F3)
 10. Select **Paste** and press **Enter**.
 - ▶ It's OK to overwrite an existing program.
 11. Press **Main Menu**.

RUN THE PROGRAM

1. Check that the probe cover is closed.
2. Ensure the key is in Run mode.
 - ▶ The door must be closed.
3. Press **Execute**. (F1)
4. Select **Hard Disk**. (F1)
5. Type your 6 digit program number and press **Enter**.
6. Set the Feed Rate Override to 0.
 - ▶ Keep you hand near the knob until the program is running without any problems.
7. Press **Cycle Start**.
8. Slowly increase the Feed Rate Override as the tool is descending towards the material.
9. Check the "To Go" Z value on the controller when the tool is descending to prevent collisions.
 - ▶ If all is well, increase to 100%.

Reduce the override after every tool change.

CLEAN UP

Stop the dust collector

1. Turn the key to Setup Mode.
2. Go to MDI mode.
3. Open the dust collection shroud.
 - ▶ **M66, Cycle Start**
4. Turn the Blast Gate switch to Off.
5. Turn off the woodshop dust collector if it's not in use.
6. Return the sign to the DMS controller.

Remove the tools

1. Jog the spindle to the door.
2. Press **USER**.
3. Press **Manual Tool Eject**.
4. Press **Enable Tool Eject**.
5. Remove the tool from the spindle.
 - ▶ Hold the tool to keep it from dropping.
 - ▶ Press and release the green button on the spindle.
6. Press **EXIT** twice to return to jog mode.
7. Place library tools back into the drawer.
8. Remove custom tools from the tool holder.
 - ▶ Put away the tool and tool holder.

Repeat for all tools.

Clean the router & surrounding area

- + Use a broom, dust pan & trash bag for the majority of the debris.
- + Use a vacuum for the details.
 - ▶ Use a vacuum labeled for the correct material.

Shut down the router

1. Check that the spindle is empty & all tools are put away.
2. Run the Goodnight program from the controller.
 - ▶ From the Main Menu, press **Execute**.
 - ▶ Press **Memory**.
 - ▶ Select the Goodnight program.
 - ▶ Press **Enter** and **Cycle Start**.
3. Open the door.
4. Throw the main power switch.
 - ▶ Get your thumb drive while you're back there.

PREPARATION

1. Remember that most of the work will happen before you get to the router.
2. Be alert and minimize distractions.
3. If you are unsure of any steps, start that section over.
 - ▶ Ask Shop Staff for help if needed.

REGENERATE TOOL PATHS AFTER MEASURING THE ACTUAL STOCK.

USING THE ROUTER

1. Insert custom tools into the holders. *(page 7)*
2. Start up the router. *(page 8)*
3. Install ξ measure tools. *(page 9)*
4. Warmup the spindle. *(page 13)*
5. Set the Work Offset (G54). *(page 11)*
6. Load the program. *(page 14)*
7. Run the program. *(page 14)*
8. Clean up. *(page 15)*

KEEP YOUR FEED RATE LOW UNTIL YOU ARE CONFIDENT IN YOUR TOOLPATH.

CLEANUP

1. Remove tool holders from the machine.
 - ▶ Put away library tools.
 - ▶ Remove and put away custom tools.
2. Use brooms, dustpans and a shop vac to clean the inside of the enclosure.
3. Close the door.
4. Turn off the router ξ get your thumb drive.
5. Clean tables and the floor.
6. Put away all tools.

PRESS THE E-STOP BEFORE ENTERING THE ENCLOSURE TO CLEAN IT.