

Step #1
Cut a 1" x 2" - 26 GA. Sterling Silver plate, file edges smooth and easy any sharpe edges.

Step #2 Sketch, with a pencil, approximate location of were the river will be flowing. Using a small ballpean hammer tap in the texture to create the ripples of the water

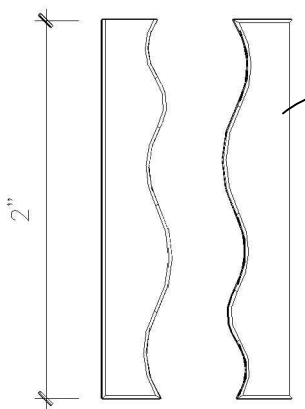

Step #3
1/ 2" x 2" - 26 GA. Sterling Silver plate. Take the plate and cut a squiqaly line down the center to resemble a river bank. Take one piece and flip it around to look upsidedown and opposite of the other piece. File cut smooth and easy sharp edges.

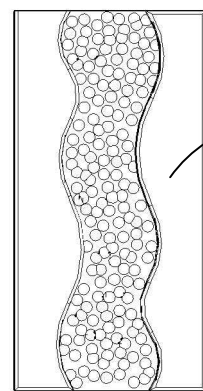
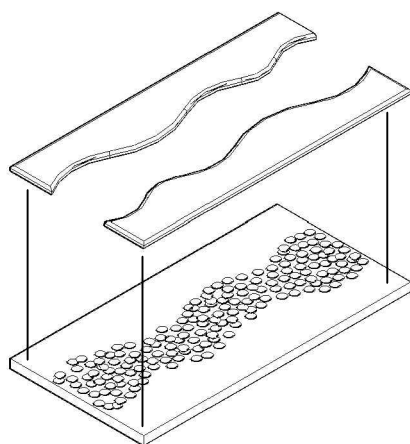

Step #4
Using the hard solder and flux, solder the two river banks onto the river plate. If the edges are slightly off, you can file the edges flush. The solder should flow to seal the edges and make it appear as one solid piece.

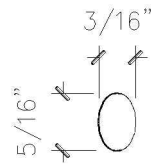

Step #5
Take bezel wire and wrap the cabochon stone with the wire. Cut the wire so it make one complete wrapping around the stone.

Step #6
Using the Flux and hard solder, solder the bezel wire seam closed. Lightly file seam smooth.

Step #7
Cut a piece of 18 gauge silver wire 3/ 8" long and bend to a half round shape. Lightly pound the wire flat to the approximate thickness of the 26 GA. plate.

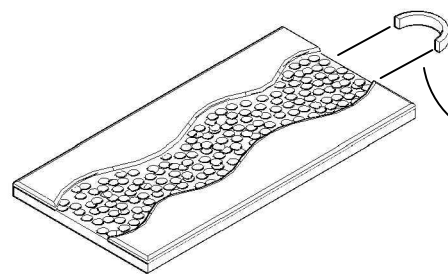

Step #8
Using flux and hard solder solder the half loop to river pendent.

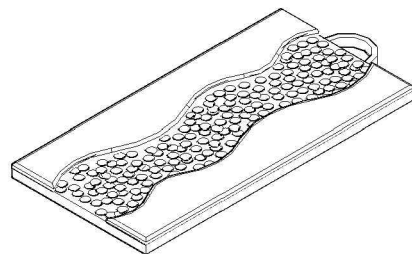

Step #9
At this point you can polish the river pendent for the first time.

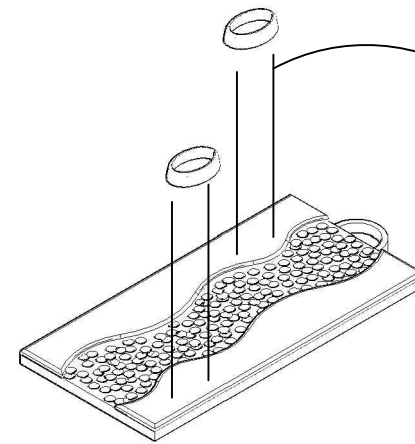

Step #10
Using flux and easy solder, solder the bezel wire into the approximate positions shown.

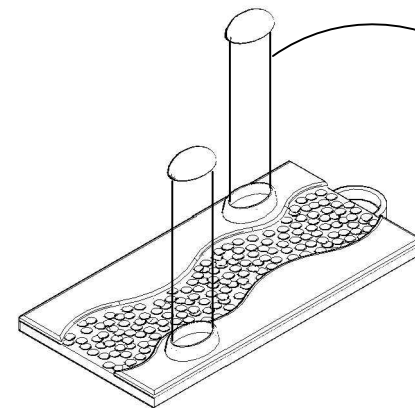

Step #11
Take the Cabochon stone and place them in the bezel wire. Then take your burnishing tool and start pressing the bezel wire down around the stone to secure the stone in place. Using the burnishing tool rub along the bezel wire until smooth.

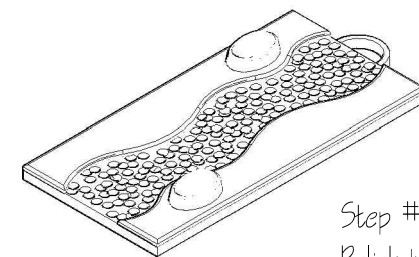

Step #12
Polish to a high gloss mirror finish

List of items need for this project

1. 26 gauge sterling silver plate
2. 1/ 8" bezel wire
3. Two Cabochon stones
4. Hard Solder
5. Easy Solder
6. 18 gauge silver wire

Tools needed for this project

1. Jewelers saw
2. Burnishing tool
3. Flux
4. Butane Torch
5. Bowl of water
6. Polishing Compond
7. Dremel tool for polishing
8. Files