

RobotArm

BY FLORIN TOBLER - 2016

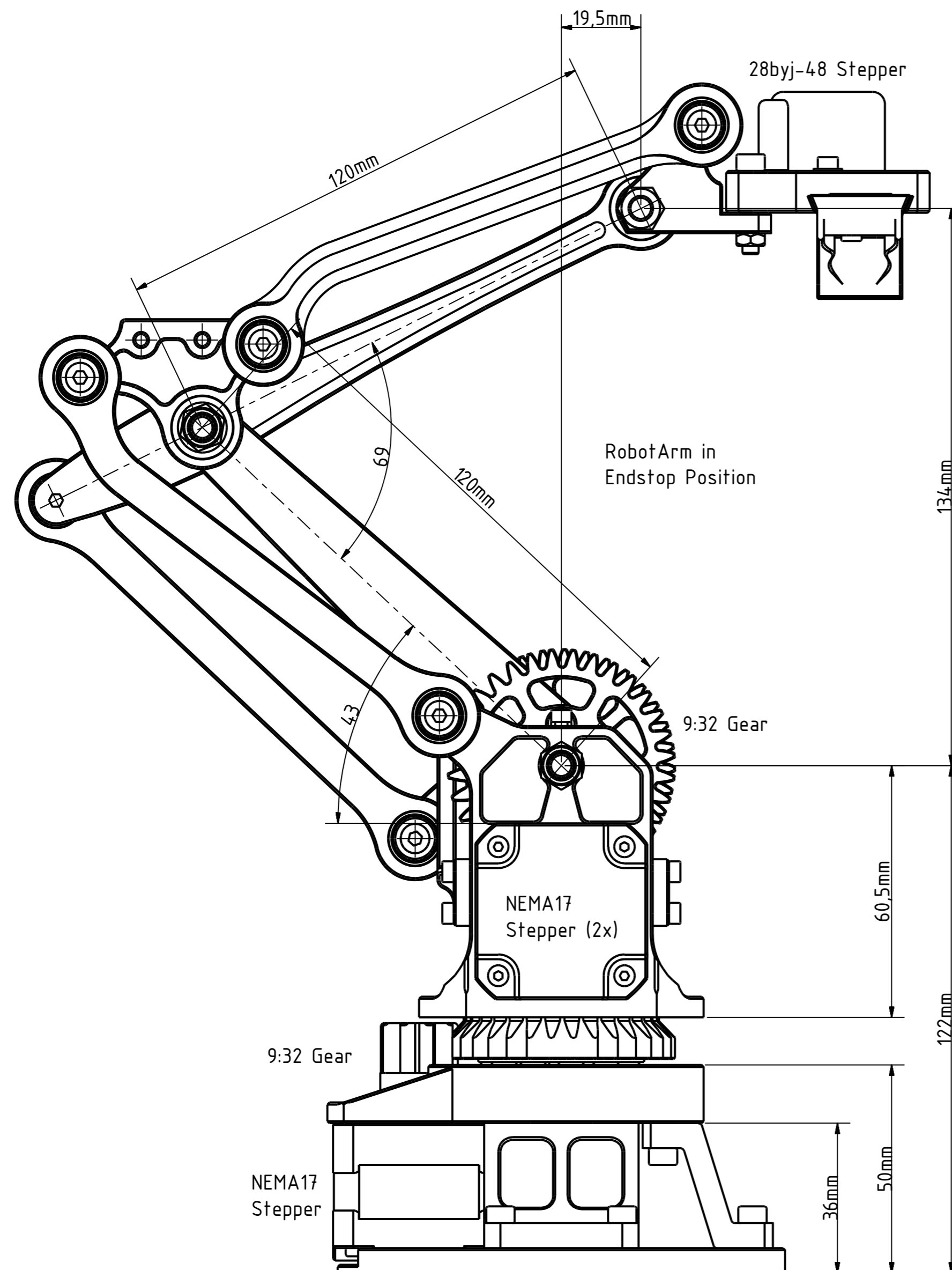

Ingredients

- 6x Bearing 4x13x5mm (624zz)
- 10x Flanged Bearing 13x6x5mm (F686zz)
- 1x Thrust Bearing 25x42x11mm (51105)
- 3x NEMA17 Stepper Motor
- 1x 28byj-48 Stepper Motor
- 1x RAMPS 1.4
- 1x Arduino Mega 2560
- 3x Stepper Driver (DRV8825 or A4988)
- several M4 and M3 Screws & Nuts..
- M5 Threaded Rod & Nuts..
- Washers, Wire, Cable ties..

Plastics

- 1x Base
- 1x stabilizer
- 1x stabilizer_endstop
- 2x GearBig
- 3x GearSmall
- 1x Lever
- 1x LowerShank
- 1x UpperShank
- 1x Manipulator
- 1x Pleuel
- 2x Pleuel_bend
- 1x triplate

- 1x gripperBase
- 2x gripperFinger
- 1x gripperHolePlate

- 1x Socket
- 1x GearRotate << look for tight fit
- 3x Leg << your preferred height
- 1x baseRing << optional

